

DIN 950-D

带旋转手柄的轮辐手轮

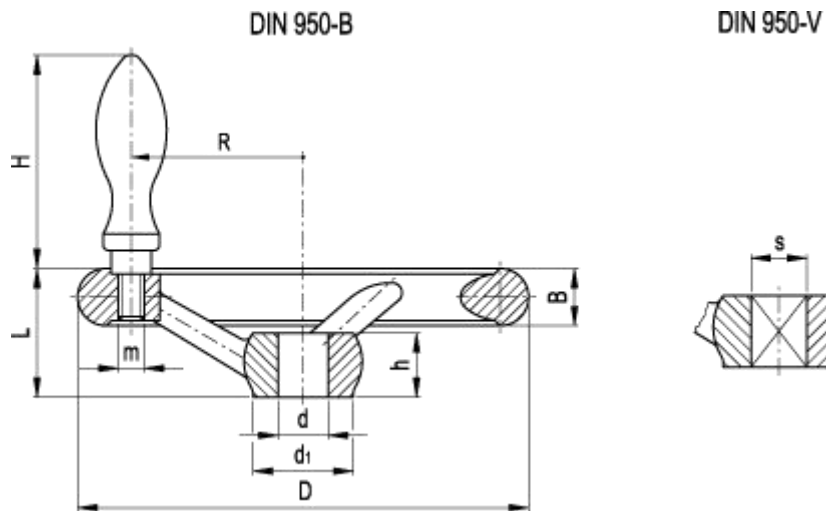

标准件	主尺寸			孔径				手柄				轮辐数	重量
	D	L	B	d ₁	d _{H7}	s _{H11}	h	H	Ø	m	R		Q12
DIN 950-GG-80-B10-D	80	29	14	24	10	-	16	53	16	M6	27	3	357
DIN 950-GG-80-B12-D	80	29	14	24	12	-	16	53	16	M6	27	3	350
DIN 950-GG-80-K10-D	80	29	14	24	10	-	16	53	16	M6	27	3	347
DIN 950-GG-80-K12-D	80	29	14	24	12	-	16	53	16	M6	27	3	340
DIN 950-GG-80-V9-D	80	29	14	24	-	9x9	16	53	16	M6	27	3	355
DIN 950-GG-100-B10-D	100	33	15	26	10	-	17	53	16	M6	36	3	554
DIN 950-GG-100-B12-D	100	33	15	26	12	-	17	53	16	M6	36	3	549

标准件	主尺寸				孔径			手柄				轮辐数	重量
说明	D	L	B	d ₁	d _{H7}	s _{H11}	h	H	Ø	m	R		Q12
DIN 950-GG-100-K10-D	100	33	15	26	10	-	17	53	16	M6	36	3	551
DIN 950-GG-100-K12-D	100	33	15	26	12	-	17	53	16	M6	36	3	546
DIN 950-GG-100-V9-D	100	33	15	26	-	9x9	17	53	16	M6	36	3	237
DIN 950-GG-125-B12-D	125	36	16	28	12	-	18	65	20	M8	47	3	768
DIN 950-GG-125-B14-D	125	36	16	28	14	-	18	65	20	M8	47	3	764
DIN 950-GG-125-K12-D	125	36	16	28	12	-	18	65	20	M8	47	3	764
DIN 950-GG-125-K14-D	125	36	16	28	14	-	18	65	20	M8	47	3	760
DIN 950-GG-125-V11-D	125	36	16	28	-	11x11	18	65	20	M8	47	3	758
DIN 950-GG-140-B14-D	140	39	17	30	14	-	19	65	20	M8	52	3	1031
DIN 950-GG-140-B16-D	140	39	17	30	16	-	19	65	20	M8	52	3	1017
DIN 950-GG-140-K14-D	140	39	17	30	14	-	19	65	20	M8	52	3	1025
DIN 950-GG-140-K16-D	140	39	17	30	16	-	19	65	20	M8	52	3	1011
DIN 950-GG-160-B14-D	160	40	18	33	14	-	20	80	25	M10	62	3	1218
DIN 950-GG-160-B16-D	160	40	18	33	16	-	20	80	25	M10	62	3	1212
DIN 950-GG-160-K14-D	160	40	18	33	14	-	20	80	25	M10	62	3	1210
DIN 950-GG-160-K16-D	160	40	18	33	16	-	20	80	25	M10	62	3	1204
DIN 950-GG-160-V12-D	160	40	18	33	-	12x12	20	80	25	M10	62	3	1208
DIN 950-GG-180-B16-D	180	43	20	35	16	-	22	80	25	M10	72	3	1778
DIN 950-GG-180-B18-D	180	43	20	35	18	-	22	80	25	M10	72	3	1770
DIN 950-GG-180-K16-D	180	43	20	35	16	-	22	80	25	M10	72	3	1769
DIN 950-GG-180-K18-D	180	43	20	35	18	-	22	80	25	M10	72	3	1761
DIN 950-GG-200-B18-D	200	45	22	38	18	-	24	80	25	M10	80	3	2335
DIN 950-GG-200-B20-D	200	45	22	38	20	-	24	80	25	M10	80	3	2327
DIN 950-GG-200-K18-D	200	45	22	38	18	-	24	80	25	M10	80	3	2325
DIN 950-GG-200-K20-D	200	45	22	38	20	-	24	80	25	M10	80	3	2317
DIN 950-GG-200-V14-D	200	45	22	38	-	14x14	24	80	25	M10	80	3	2331

标准件	主尺寸				孔径			手柄				轮辐数	重量
说明	D	L	B	d ₁	d _{H7}	s _{H11}	h	H	Ø	m	R		Q12
DIN 950-GG-250-B22-D	250	50	26	45	22	-	28	102	32	M12	101	5	4174
DIN 950-GG-250-B24-D	250	50	26	45	24	-	28	102	32	M12	101	5	4156
DIN 950-GG-250-K22-D	250	50	26	45	22	-	28	102	32	M12	101	5	4163
DIN 950-GG-250-K24-D	250	50	26	45	24	-	28	102	32	M12	101	5	4145
DIN 950-GG-250-V17-D	250	50	26	45	-	17x17	28	102	32	M12	101	5	4236
DIN 950-GG-315-B26-D	315	56	28	53	26	-	33	102	32	M12	132	5	6360
DIN 950-GG-315-B30-D	315	56	28	53	30	-	33	102	32	M12	132	5	6319
DIN 950-GG-315-K26-D	315	56	28	53	26	-	33	102	32	M12	132	5	6492
DIN 950-GG-315-K30-D	315	56	28	53	30	-	33	102	32	M12	132	5	6476
DIN 950-GG-315-V19-D	315	56	28	53	-	19x19	33	102	32	M12	132	5	6520
DIN 950-GG-400-B30-D	400	63	32	65	30	-	38	102	32	M12	171	5	10813
DIN 950-GG-400-B34-D	400	63	32	65	34	-	38	102	32	M12	171	5	10720
DIN 950-GG-400-K30-D	400	63	32	65	30	-	38	102	32	M12	171	5	10799
DIN 950-GG-400-K34-D	400	63	32	65	34	-	38	102	32	M12	171	5	10706
DIN 950-GG-400-V24-D	400	63	32	65	-	24x24	38	102	32	M12	171	5	10984
DIN 950-GG-500-B34-D	500	72	34	78	34	-	45	102	32	M12	220	5	15764
DIN 950-GG-500-B40-D	500	72	34	78	40	-	45	102	32	M12	220	5	15604
DIN 950-GG-500-K34-D	500	72	34	78	34	-	45	102	32	M12	220	5	15749
DIN 950-GG-500-K40-D	500	72	34	78	40	-	45	102	32	M12	220	5	15589
DIN 950-GG-500-V27-D	500	72	34	78	-	27x27	45	102	32	M12	220	5	15952
DIN 950-AL-80-B10-D	80	29	14	24	10	-	16	53	16	M6	27	3	158
DIN 950-AL-80-B12-D	80	29	14	24	12	-	16	53	16	M6	27	3	154
DIN 950-AL-80-K10-D	80	29	14	24	10	-	16	53	16	M6	27	3	156
DIN 950-AL-80-K12-D	80	29	14	24	12	-	16	53	16	M6	27	3	152
DIN 950-AL-80-V9-D	80	29	14	24	-	9x9	16	53	16	M6	27	3	156
DIN 950-AL-100-B10-D	100	33	15	26	10	-	17	53	16	M6	36	3	238

标准件	主尺寸				孔径			手柄				轮辐数	重量
说明	D	L	B	d ₁	d _{H7}	s _{H11}	h	H	Ø	m	R		Q12
DIN 950-AL-100-B12-D	100	33	15	26	12	-	17	53	16	M6	36	3	234
DIN 950-AL-100-K10-D	100	33	15	26	10	-	17	53	16	M6	36	3	236
DIN 950-AL-100-K12-D	100	33	15	26	12	-	17	53	16	M6	36	3	232
DIN 950-AL-100-V9-D	100	33	15	26	-	9x9	17	53	16	M6	36	3	237
DIN 950-AL-125-B12-D	125	36	16	28	12	-	18	65	20	M8	47	3	344
DIN 950-AL-125-B14-D	125	36	16	28	14	-	18	65	20	M8	47	3	341
DIN 950-AL-125-K12-D	125	36	16	28	12	-	18	65	20	M8	47	3	342
DIN 950-AL-125-K14-D	125	36	16	28	14	-	18	65	20	M8	47	3	399
DIN 950-AL-125-V11-D	125	36	16	28	-	11x11	18	65	20	M8	47	3	342
DIN 950-AL-140-B14-D	140	39	17	30	14	-	19	65	20	M8	52	3	400
DIN 950-AL-140-B16-D	140	39	17	30	16	-	19	65	20	M8	52	3	378
DIN 950-AL-140-K14-D	140	39	17	30	14	-	19	65	20	M8	52	3	437
DIN 950-AL-140-K16-D	140	39	17	30	16	-	19	65	20	M8	52	3	435
DIN 950-AL-160-B14-D	160	40	18	33	14	-	20	80	25	M10	62	3	602
DIN 950-AL-160-B16-D	160	40	18	33	16	-	20	80	25	M10	62	3	597
DIN 950-AL-160-K14-D	160	40	18	33	14	-	20	80	25	M10	62	3	599
DIN 950-AL-160-K16-D	160	40	18	33	16	-	20	80	25	M10	62	3	594
DIN 950-AL-160-V12-D	160	40	18	33	-	12x12	20	80	25	M10	62	3	600
DIN 950-AL-180-B16-D	180	43	20	35	16	-	22	80	25	M10	72	3	755
DIN 950-AL-180-B18-D	180	43	20	35	18	-	22	80	25	M10	72	3	751
DIN 950-AL-180-K16-D	180	43	20	35	16	-	22	80	25	M10	72	3	755
DIN 950-AL-180-K18-D	180	43	20	35	18	-	22	80	25	M10	72	3	751
DIN 950-AL-200-B18-D	200	45	22	38	18	-	24	80	25	M10	80	3	954
DIN 950-AL-200-B20-D	200	45	22	38	20	-	24	80	25	M10	80	3	936
DIN 950-AL-200-K18-D	200	45	22	38	18	-	24	80	25	M10	80	3	950
DIN 950-AL-200-K20-D	200	45	22	38	20	-	24	80	25	M10	80	3	932

标准件	主尺寸				孔径			手柄				轮辐数	重量
说明	D	L	B	d ₁	d _{H7}	s _{H11}	h	H	Ø	m	R		Q12
DIN 950-AL-200-V14-D	200	45	22	38	-	14x14	24	80	25	M10	80	3	970
DIN 950-AL-250-B22-D	250	50	26	45	22	-	28	102	32	M12	101	5	1811
DIN 950-AL-250-B24-D	250	50	26	45	24	-	28	102	32	M12	101	5	1801
DIN 950-AL-250-K22-D	250	50	26	45	22	-	28	102	32	M12	101	5	1806
DIN 950-AL-250-K24-D	250	50	26	45	24	-	28	102	32	M12	101	5	1794
DIN 950-AL-250-V17-D	250	50	26	45	-	17x17	28	102	32	M12	101	5	1815
DIN 950-AL-315-B26-D	315	56	28	53	26	-	33	102	32	M12	132	5	2712
DIN 950-AL-315-B30-D	315	56	28	53	30	-	33	102	32	M12	132	5	2695
DIN 950-AL-315-K26-D	315	56	28	53	26	-	33	102	32	M12	132	5	2630
DIN 950-AL-315-K30-D	315	56	28	53	30	-	33	102	32	M12	132	5	2620
DIN 950-AL-315-V19-D	315	56	28	53	-	19x19	33	102	32	M12	132	5	2722
DIN 950-AL-400-B30-D	400	63	32	65	30	-	38	102	32	M12	171	5	4221
DIN 950-AL-400-B34-D	400	63	32	65	34	-	38	102	32	M12	171	5	4178
DIN 950-AL-400-K30-D	400	63	32	65	30	-	38	102	32	M12	171	5	4212
DIN 950-AL-400-K34-D	400	63	32	65	34	-	38	102	32	M12	171	5	4169
DIN 950-AL-400-V24-D	400	63	32	65	-	24x24	38	102	32	M12	171	5	4238
DIN 950-AL-500-B34-D	500	72	34	78	34	-	45	102	32	M12	220	5	6032
DIN 950-AL-500-B40-D	500	72	34	78	40	-	45	102	32	M12	220	5	5962
DIN 950-AL-500-K34-D	500	72	34	78	34	-	45	102	32	M12	220	5	6022
DIN 950-AL-500-K40-D	500	72	34	78	40	-	45	102	32	M12	220	5	5952
DIN 950-AL-500-V27-D	500	72	34	78	-	27x27	45	102	32	M12	220	5	6057

Technical information

材料

- GG 型：球墨铸铁、车削处理和镜面光亮轮缘。

- AL 型：铸铝、车削处理和光亮轮缘。

装配

- B 型：标准 H7 铰孔。

- K 型：标准 H7 铰孔和键槽，符合 **DIN 6885/1 P9 规定的公差**（参见第 A17 页）。

- V 型：标准 H11 方形安装孔（不供应 D=140 和 D=180 型）

可用埋头螺钉将 DIN950-D 型轮辐手轮固定安装在轴上，参见**技术说明**。

旋转手柄

- GG 型：DIN98 型（参见第 400 页）车削处理和镜面光亮钢材。 - AL 型：DIN98 型（参见第 400 页）黑色聚酰胺基（PA）高科技聚合体。

按需可有以下附件备选

GN 184 型轴向定位垫圈（参见第 631 页）。